

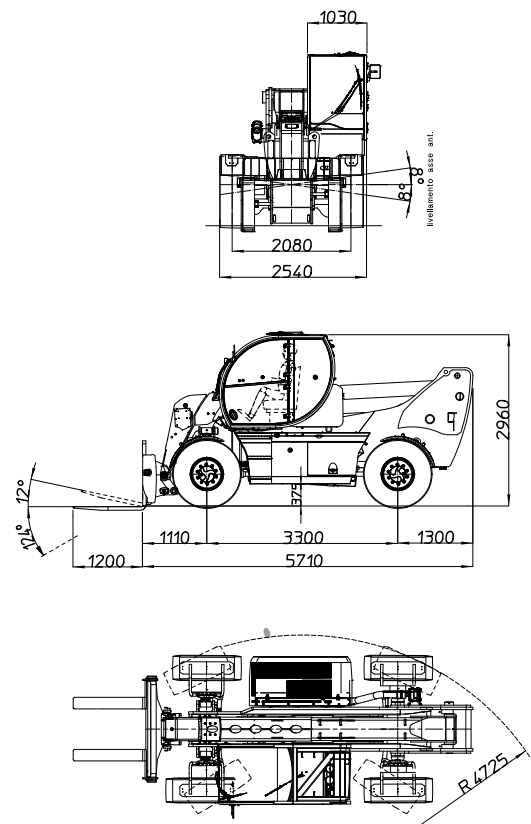

## HTH10.10

Load chart forklift with fork

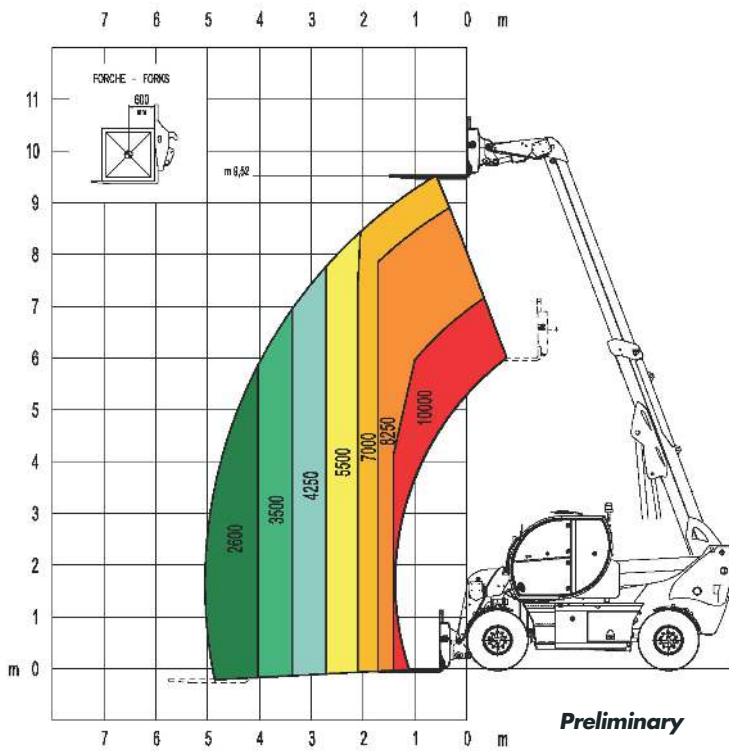

Clamp for wheels handling, with a capacity up to 8.000 kg from 24 to 63 inches .

- MAGNI patented quick fit of the attachment
- Attachments automatic recognition RFID system



<b>LIFT CAPACITY</b>	10.000 Kg at 600 mm load center	
<b>MAXIMUM LIFTING HEIGHT</b>	9.52m	
<b>MAXIMUM REACH</b>	5.05 m	
<b>FORKS</b>	Fork carriage with forks positioner 1.750 mm length	
	Forks 200x60x1.200 mm	
<b>CAB</b>	FOPS-ROPS tested hermetic cab with protectors	
	Front, rear and upper wiper	
	Headlights for road circulation, flashing beacon	
	Rear view mirrors	
	Heating - Air conditioning	
<b>CONTROLS</b>	Multi-function electro proportional joystick	
<b>BRAKE SYSTEM</b>	Hydraulic servo-assisted multidisc brake in oil bath on both axles, with double circuit	
	Negative parking brake	
<b>ENGINE</b>	Mercedes OM 924 LA - stage 3B	Mercedes OM 924 LA - stage 3A
	Turbo intercooler	
	4 cylinders / 4.800 cm <sup>3</sup>	4 cylinders / 4.250 cm <sup>3</sup>
	Power 115 KW	Power 110 KW
	Max rpm = 2.200	
	Max torque 610 Nm at 1.400 rpm	Max torque 580 Nm at 1.400 rpm
	Diesel turbocharged	
	Liquid cooling system	
<b>AXLES</b>	Heavy Duty with epicyclic reduction	
	One steering cylinder each axle	
	Levelling correction front axle at + 8° on the right and + 8° on the left	
	3 types of steering: - with front steering - with round steer - with crab steering	
	Tilting rear axle	
<b>PERFORMANCE</b>	Max. travel speed: 40 km/h	
	Drawbar pull: 88 kN	
	Gradeability: 35%	
	Turning radius (end of forks): 4.725 mm	
<b>WEIGHTS</b>	Total unladen: 13.900 kg	
	Front axle unladen (boom retracted and lowered): 6.300 kg	
	Rear axle unladen (boom retracted and lowered): 7.600 kg	
<b>TRANSMISSION</b>	Rexroth hydrostatics	
	Variable displacement hydrostatic pump 85 cc with electronic control	
	One variable displacement hydrostatic motor 115 cc	
	Hydraulic gearbox with 2 speeds forward / reverse	
<b>HYDRAULIC CIRCUIT</b>	Load sensing piston pump 60 cc 132 l/min	
	Circuit at 350 bar	
	Electroproportional valve	
	Suction and return line filters	
	High pressure flexible hoses	
<b>TANKS CAPACITIES</b>	Engine oil = 16 l	
	Colling liquid = 20 l	
	Hydraulic oil tank = 210 l	
	Fuel tank = 200 l	
<b>TYRES DIMENSIONS</b>	445/65 - R22,5 two each axle, driving and steering	
<b>SAFETY</b>	Electronic safety system which controls the load with definition of the lifted load, radius and comparison with the diagrams stored.	
	Block of aggravating movements of the load.	
	Safety valves on cylinders	

The data in this brochure are informative and subject to change without notice