

LIFT CAPACITY	16.000 Kg at 600 mm load center	
MAXIMUM LIFTING EIGHT	9,70 m	
MAXIMUM REACH	5,10 m	
FORKS	Fork carriage with forks positioner device 1.950 mm width Forks 200 x 80 x 1.500 mm	
CAB	FOPS-ROPS tested hermetic cab with protectors Front, rear and upper wiper Headlights for road circulation, flashing beacon Rear view mirrors Heating - Air conditioning	
CONTROLS	Multi-function electro proportional joystick	
BRAKE SYSTEM	Hydraulic servo-assisted multidisc brake in oil bath on both axles, with double circuit Negative parking brake	
ENGINE	Mercedes OM 924 LA Euro 4 Interim	Mercedes OM 904 LA Euro 3A
	Turbo intercooler	Turbo intercooler
	4 cylinders / 4.800 cm3	4 cylinders / 4.250 cm3
	Power 156 HP – 115 KW	Power 150 HP – 110 KW
	Max rpm = 2.200	Max rpm = 2.200
	Max torque 610 Nm at 1.200 - 1.600 rpm	Max torque 580 Nm at 1.200 - 1.600 rpm
	Electronic injection (single pump each injector)	Electronic injection (single pump each injector)
	Water + intercooler	Water + intercooler
AXLES	Heavy Duty with 4-stage epicyclic reduction One steering cylinder each axle Levelling correction front axle at + 8° on the right and + 8° on the left 3 types of steering: - with front steering - with round steer - with crab steering Tilting rear axle	
PERFORMANCE	Max. travel speed: 25 km/h Drawbar pull: 114 kn Gradeability: 35% Turning radius (end of forks): 5.510 mm	
WEIGHTS	Total unladen: 20.200 kg Front axle unladen (boom retracted and lowered): 8.700 kg Rear axle unladen (boom retracted and lowered): 11.500 kg	
TRANSMISSION	Rexroth hydrostatics Variable displacement hydrostatic pump 110 cc with electronic control One variable displacement hydrostatic motor 150 cc Hydraulic gearbox with 2 speeds forward / reverse Differential hydraulic locking	
HYDRAULIC CIRCUIT	Load sensing piston pump 60 cc 132 l/min Circuit at 350 bar Rexroth Proportional hydraulic distributor Suction and return line filters High pressure flexible hoses	
TANKS CAPACITIES	Engine oil = 16 l cooling liquid = 25 l Ad Blue = 40 l Hydraulic oil tank = 210 l Fuel tank = 200 l	Engine oil = 16 l cooling liquid = 25 l Hydraulic oil tank = 210 l Fuel tank = 200 l
TYRES DIMENSIONS	16.00 - R25 ** two each axle, driving and steering Goodyear EV-3+	
SAFETY	Electronic safety system which controls the load with definition of the lifted load, radius and comparison with the diagrams stored. Block of aggravating movements of the load. Safety valves on cylinders	

The data in this brochure are informative and subject to change without notice



Maximum lift capacity: 16 t at 600 mm load center
Maximum lifting height: 9,70 m
Maximum reach: 5,10 m
Mercedes engine: 115 KW - 156 HP
Electronically controlled hydrostatic transmission

HTH16.10



Pressurized cab ISO 10.263
 Standard air conditioning and heating
 Touch screen display with joystick control system

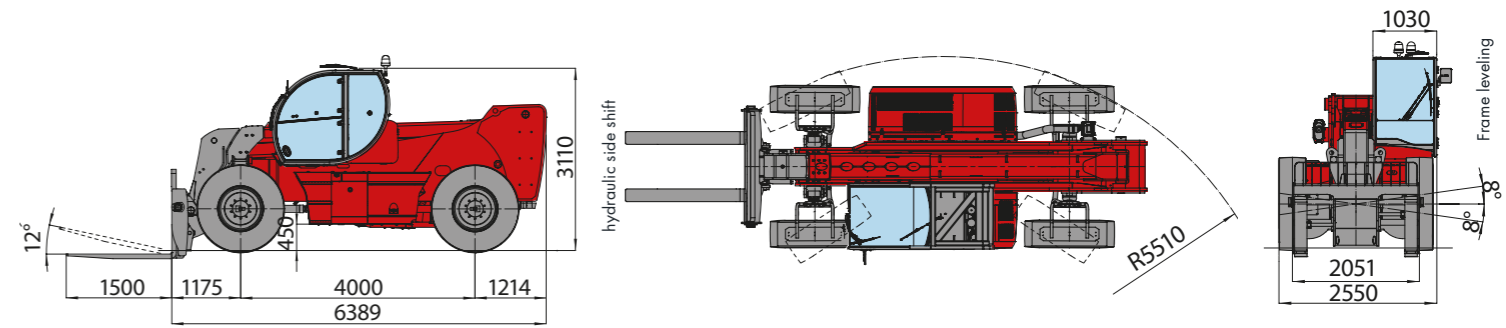

Load chart forkcarriage with forks positioner

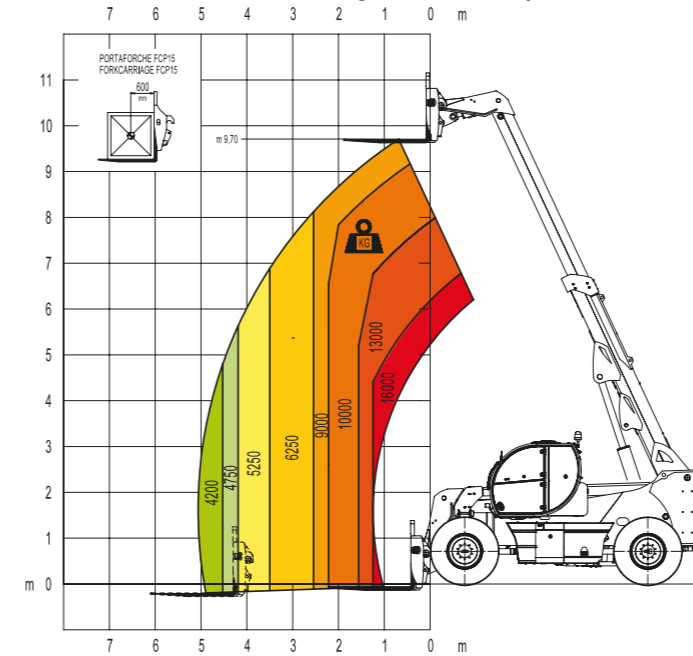

Load chart with wheels clamp

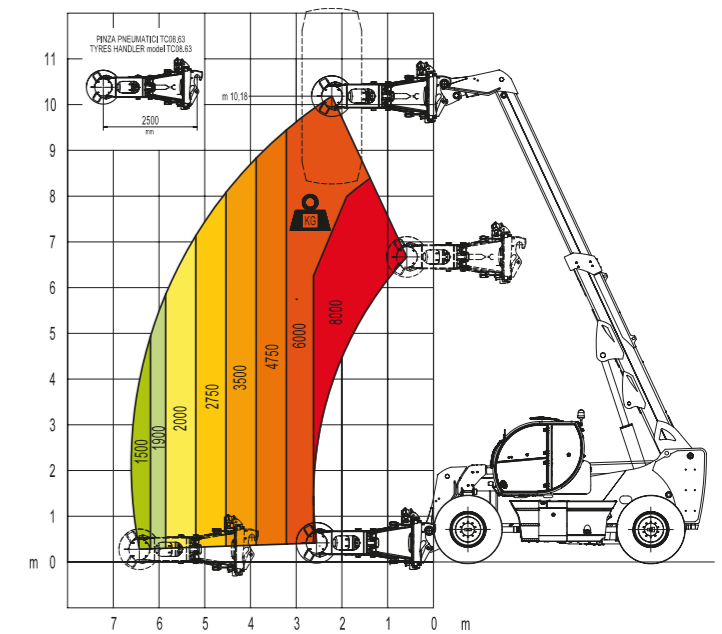

Clamp for wheels handling, with a capacity up to 16.000 kg from 24 to 63 inches .



From the left:

- Travelling mode screen
- Load Moment Indicator screen
- Air conditioning management screen

- MAGNI patented quick fit of the attachment
- Attachments automatic recognition RFID system

